

PCD3.A810

Digital manual control module with 4 relays, 2 with changeover, 2 with make contacts

The module has 4 relay outputs: 2 changeover and 2 make contacts. Each channel has a switch with the settings MAN 1, AUTO, MAN 0. On MAN 0, the relay is always switched off; on MAN 1 it is always switched on; on AUTO the switch state is defined by the application program. This is not an emergency module that will work even when the Saia PCD® is switched off (or defective). The external 24 V supply feeds only the relays, and not the logic.

For space reasons, there is no integrated contact protection (for emergency and manual operation, see also Document "27-600 Manual I/O-Modules PCD1/2/3", Appendix A.6.4).

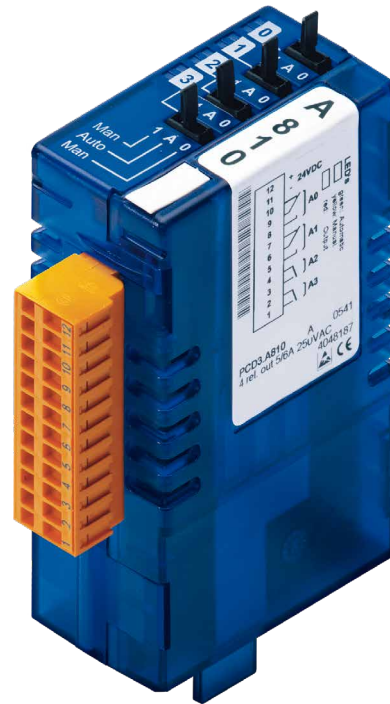

Technical data	
Number of outputs	4 relays (2 changeover and 2 make contacts)
Relay type changeover	PE 01 4024, SCHRACK
Operating mode	> 12 V, > 100 mA
Max. switching current	5 A, 250 VAC AC1
Contact lifetime ¹⁾	5 A, 250 VAC AC1 1,5 × 10 ⁵ Schaltungen 2 A, 250 VAC AC15 1,2 × 10 ⁵ Schaltungen cosφ = 0.3
Relay type make	RE 03 0024, SCHRACK
Operating mode	> 12 V, > 100 mA
Max. switching current	6 A 250 VAC AC1
Contact lifetime ¹⁾	6 A, 250 VAC AC1 1 × 10 ⁵ Schaltungen 2 A, 250 VAC AC11 4 × 10 ⁵ Schaltungen
Switching delay	typically 5 ms bei 24 VDC
Internal current consumption: (from +5 V bus)	max. 45 mA
Internal current consumption: (from V+ bus)	0 mA
External current consumption	max. 45 mA
Relay coil supply	nom. 24 VDC smoothed or pulsed, reverse voltage protected
Voltage tolerance, dependent on ambient temperature	20 °C: 21.5 ... 32 VDC 30 °C: 21.9 ... 32 VDC 40 °C: 22.3 ... 32 VDC 50 °C: 22.8 ... 32 VDC
Isolation	
Withstand voltage - coil contacts	4 kV (relay details)
Withstand voltage - open contact circuit	1 kV (relay details)
Terminals	Plug-in 12-pole spring terminal block (4 405 4936 0), for Ø up to 1.5 mm ²

¹⁾ The supply to the relay coils is not electrically isolated from the Saia PCD® side. General technical specifications as per CL-EPC-015 Rev. 02

¹⁾ There are no suppressors fitted to the module; these must be provided externally!

Operation

Each channel (output) has a toggle switch with three switching positions:

- 1 = Manual on
- A = Auto
- 0 = Manual off

Two LEDs per channel:

LED	Color	Meaning
upper	two-tone (amber/green)	amber = Manual green = Automatik
lower	monochrome (red)	red = Relais erregt off = Relais aus

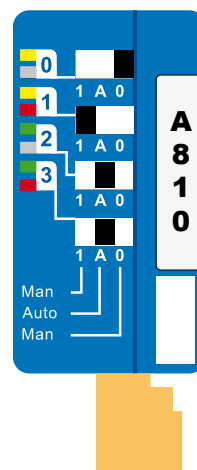

Example see left:

Channel	Action	Display
0	Manual off Relay off	LED 1 = amber LED 2 = off
1	Manual on Relay on	LED 1 = amber LED 2 = red
2	Automatic Relay on	LED 1 = green LED 2 = off
3	Automatic Relay on	LED 1 = green LED 2 = red

If the external supply for the relay coils is not available, the LED does not light up and the relays are not energised.

There is no error message for the Saia PCD® if there is no power supply.

Terminal designation

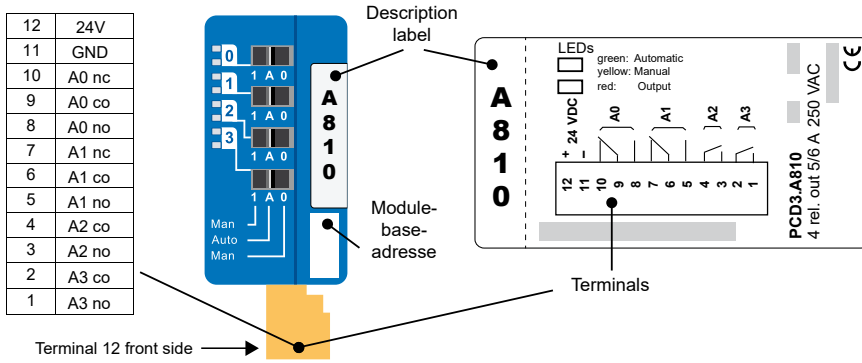

Block schematic

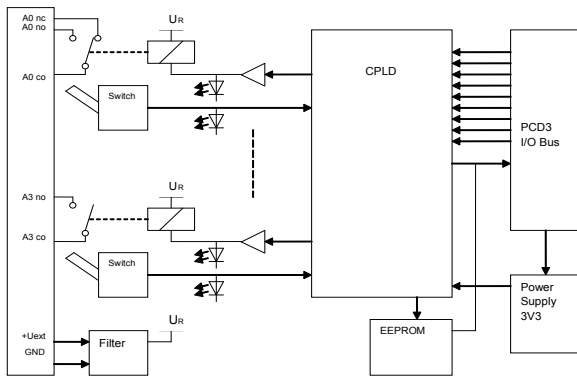

Function description

No FBs or FBoxes are required; the module can be addressed in the same way as a normal relay module. At addresses 0...3, the relay outputs are written to and the effective switch state of the outputs is read back.

The effective switch state is displayed at these addresses in manual operation also. However, the display of the switch state does not indicate whether the external relay supply is present - just as with normal output modules.

The operating mode (Auto or Manual) for each channel can be read at input addresses 8...11; "0" = Auto; "1" = Man.



Watchdog: This module can be used on all base addresses; there is no interaction with the watchdog on the CPUs.



Further information can be found in the document "27-600 Manual I/O Modules"



I/O modules and I/O terminal blocks may only be plugged in and removed when the Saia PCD® and the external +24 V are disconnected from the power supply.

Ordering information

Type	Short description	Description	Weight
PCD3.A810	Manual control module with 4 relays outputs	Digital manual control module with 4 relays 2 with changeover, 2 with make contacts connector type F (4 405 4936 0) included	100 g

Ordering information equipment

Type	Short description	Description	Weight
4 405 4936 0	Plug-in, type F	Plug-in I/O spring terminal block, 12-pole up to 1.5 mm ² , labelled 1 to 12, for manual control module PCD3.A810	15 g

Honeywell | Partner Channel

Saia-Burgess Controls AG

Bahnhofstrasse 18 | 3280 Murten, Switzerland
T +41 26 580 30 00 | F +41 26 580 34 99
www.saia-pcd.com

support@saia-pcd.com | www.sbc-support.com